

Macadams Belshaw Donut Robots



MARK 1



FILTER FLO



FINISHING TREE

FEATURES & BENEFITS

- ELECTRICALLY POWERED CONVEYOR.
- FRYING TIME & TEMPERATURE ADJUSTMENT.
- THE DONUT ROBOT[®] AUTOMATIC CAKE DONUT DEPOSITOR IS STANDARD.
- ELECTRIC HEATED.
- CONVEYOR ROW SPACING: 95 cm.



Technical Specs

Macadams Belshaw Donut Robots

Contact Details

HEAD OFFICE, EXPORTS & CAPE TOWN BRANCH

Private Bag X7, Kuils River, 7579, South Africa.

Tel : +27 (21) 907-1000

Fax : +27 (21) 907-1111

JOHANNESBURG BRANCH

Tel : (011) 472-4100

Fax : (011) 472-4154

DURBAN BRANCH

Tel : (031) 569-6290

Fax : (031) 569-6296

EMAIL

info@macadams.co.za

WEBSITE

www.macadams.co.za

We reserve the right to both technical and design modifications.

February 2009

	MARK 1	MARK 2
Output @ 95 second frying time	13 dozen p/hr	42 dozen p/hr
Electrics	120V, 50/60Hz, 1.2 kW, 10 Amps, single phase OR 208/240V, 50/60Hz, 1.5 kW, 7.4/6.4 Amps, single phase	208/240 V, 50/60 Hz, 4.3/5.7 kW, 21.0/24.0 Amp, single phase OR 208/240 V, 50/60 Hz, 4.5/5.7 kW, 12.5/14.2 Amp, 3 phase
Oil Weight	6.4 kg	16 kg
Dimensions (mm)	890 (l) x 340 (d) x 570 (h)	1040 (l) x 520 (d) x 620 (h)
Weight	45 kg	66 kg

MARK 1

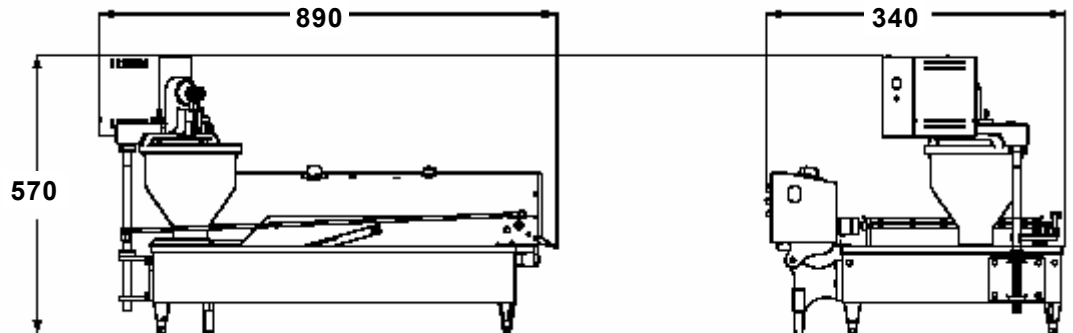

MARK 2

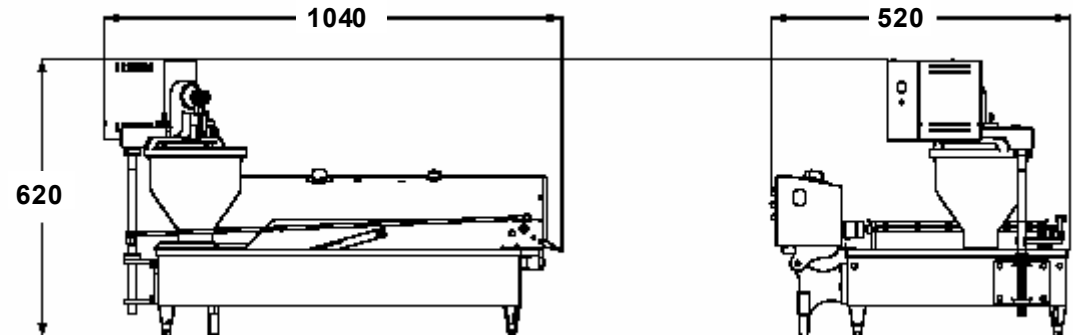

The Company. The People. The Products.

