

Macadams Doughnut Fryers



FEATURES & BENEFITS

- SUITED FOR SMALL & MEDIUM SIZED BAKERIES.
- DURABLE STAINLESS STEEL CONSTRUCTION.
- THERMOSTATICALLY CONTROLLED.
- SUPPLIED COMPLETE WITH A DRIP TRAY, 2 BASKETS AND OIL DRAIN TAP.
- REMOVABLE HEATING ELEMENT.
- SAFE & EASY TO OPERATE.
- EASY TO MAINTAIN.



Technical Specs

Macadams Doughnut Fryers

	MAC EXPORT	MAC 50
Power Rating:		
Fryer	3.9 kW	6.0 kW
Under Prover (Optional)	0.5 kW	0.5 kW
Supply Voltage	380V, 3 phase, neutral and earth.	
Control Voltage	220 V	
Outlet	25 mm	
Oil Capacity	15 litres	35 litres
Doughnut Capacity	20 – 24	35 – 40
Options	Under prover	

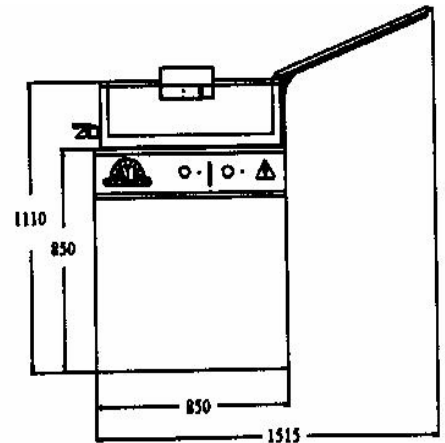
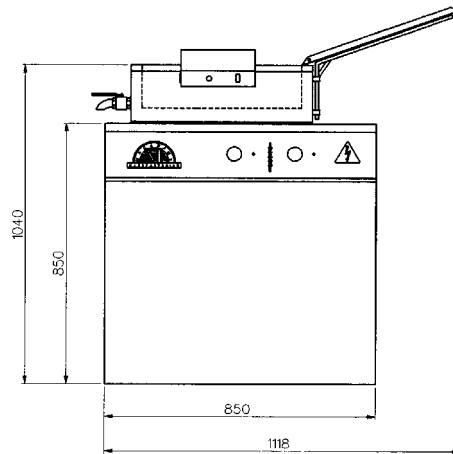

Contact Details

HEAD OFFICE, EXPORTS & CAPETOWN BRANCH

Private Bag X7, Kuils River, 7579, South Africa.

Tel : +27 (21) 907-1000

Fax : +27 (21) 907-1111

JOHANNESBURG BRANCH

Tel : (011) 472-4100

Fax : (011) 472-4154

DURBAN BRANCH

Tel : (031) 569-6290

Fax : (031) 569-6296

EMAIL

info@macadams.co.za

WEBSITE

www.macadams.co.za

We reserve the right to both technical and design modifications.

February 2009

The Company. The People. The Products.

