

Status Universal Machines



200 XL



200

FEATURES & BENEFITS

- ONE MAN OPERATION.
- MOBILE & FLEXIBLE WITH 4 WHEELS.
- CONVEYOR SYSTEM WITH TWO STAINLESS STEEL CHAINS.
- EFFICIENT CLEANING OF PLASTIC CRATES, BASKETS, BAKING TRAYS, UTENSILS, PANS, ETC.



Technical Specs

Status Universal Machines

	200	200 XL	200 TD
Capacity:			
Crates p/hr	150 - 250	250 - 300	150 - 300
Wash Tank	150 L	215 L	-
Pump	3 kW	6 kW	-
Electric Connection	21 kW	24 kW	4 kW
Power Supply	400V, 50 Hz, neutral.		
Fuses	32 Amps	50 Amps	16 Amps
Tank Heating	2 x 6 kW	2 x 6 kW	-
Water:			
Circulation	950 L/min	2 x 950 L/min	-
Consumption	360 L	400 - 840 L	-
Water Connection (R")	1/2	1/2	-
High Pressure Blower (m3/h)	-	-	2 x 2450
Water Drain Ø (mm)	50	50	32
Dimensions: (mm)			
Tunnel run-through	460 (w) x 470 (h)	650 (w) x 470 (h)	460 - 650 (w) x 470 (h)

Contact Details

HEAD OFFICE, EXPORTS & CAPETOWN BRANCH

Private Bag x7, Kuils River, 7579,
South Africa.

Tel : +27 (21) 907-1000

Fax : +27 (21) 907-1111

JOHANNESBURG BRANCH

Tel : (011) 472-4100

Fax : (011) 472-4154

DURBAN BRANCH

Tel : (031) 569-6290

Fax : (031) 569-6296

EMAIL

info@macadams.co.za

WEBSITE

www.macadams.co.za

We reserve the right to both technical and design modifications.

February 2009

200 / 200 XL

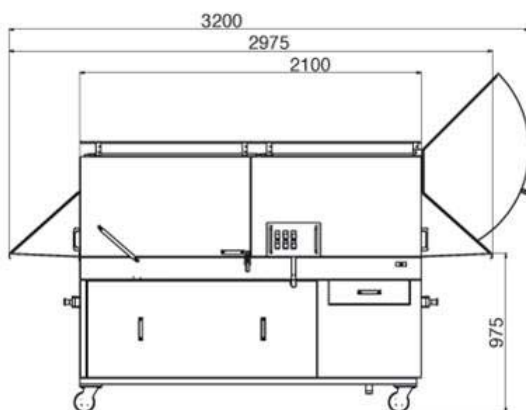

200

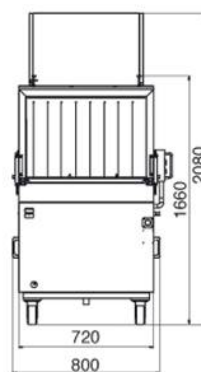

200 XL

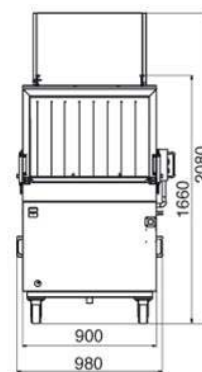

200 TD

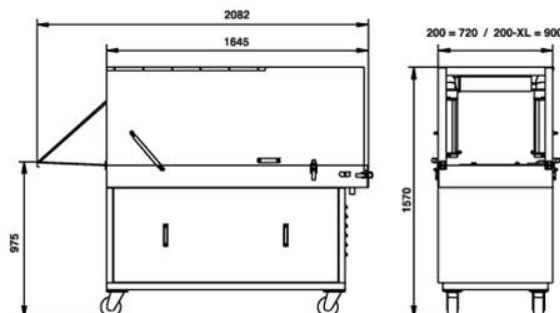

The Company. The People. The Products.

