

Macadams Chicken Grillers



FEATURES & BENEFITS

- 4 STAGE COOKING WITH HOLDING CYCLE.
- CONVECTION & RADIANT HEAT, PLUS SELF BASTING ACTION.
- DOUBLE GLAZED, CURVED, TEMPERED GLASS DOORS.
- REMOVABLE ROTORS, SPLIT & DRIP TRAYS.
- STAINLESS STEEL INTERIOR & EXTERIOR.
- 7 BASKETS.
- MODULAR CONSTRUCTION.
- NAFEM PROTOCOL CONTROLS.
- SINGLE OR INDIVIDUAL CONNECTIONS.
- STACKABLE USING NYLON CASTERS.



Technical Specs

Macadams Chicken Grillers

	HR7E
Electrical	208V, 1 phase, 60 Hz, 9.3 Watt, 42.8 Amp or 240V, 1 phase, 60 Hz, 9.3 Watt, 38.8 Amp or 208V, 3 phase, 60 Hz, 9.3 Watt, 24.7 Amp or 240V, 3 phase, 60 Hz, 9.3 Watt, 22.4 Amp
Split Motor Rotation	2 R.P.M
Capacity	28 - 35 chickens
Dimensions (mm)	988 (w) x 845 (d) x 975 (h)
Net Weight:	
Glass Back	193 kg
Solid Back	186 kg
Shipment Weight:	
Glass Back	218 kg
Solid Back	211 kg

Cooking Time:

Whole: 60 minutes

Pieces: 45 minutes

Weight Loss: 18 - 20%

Water is put into the drip tray acting as a humidifier, which results in a moist chicken.

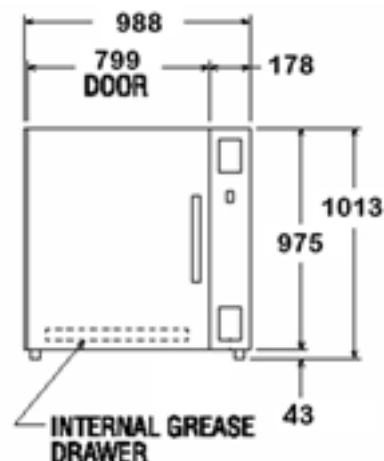
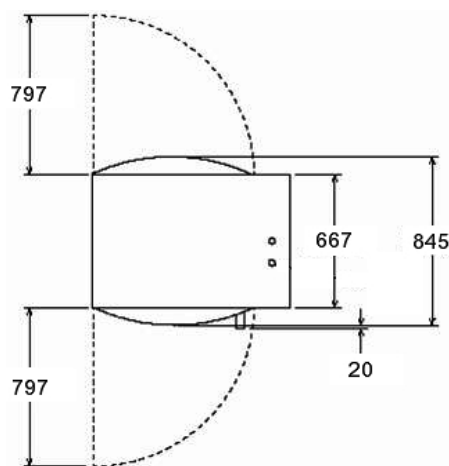

Contact Details

HEAD OFFICE, EXPORTS & CAPE TOWN BRANCH

Private Bag x7, Kuils River, 7579,
South Africa.

Tel : +27 (21) 907-1000 Fax :

+27 (21) 907-1111

JOHANNESBURG BRANCH

Tel : (011) 472-4100

Fax : (011) 472-4154

DURBAN BRANCH

Tel : (031) 569-6290

Fax : (031) 569-6296

EMAIL

info@macadams.co.za

WEBSITE

www.macadams.co.za

We reserve the right to both
technical and design
modifications.

February 2009

The Company. The People. The Products.

