

Macadams AM 900 Dishwasher



FEATURES & BENEFITS

- HOOD-TYPE DISHWASHER FOR PASS THROUGH OR CORNER OPERATION.
- ELECTRONIC CONTROL: SMARTRONIC.
- OPTIMUM HYGIENE SAFETY & SERVICE ACCESSIBILITY.
- EQUIPPED WITH RINSE AGENT DISPENSER, DETERGENT DISPENSER, RINSE PRESSURE PUMP & DRAIN PUMP.
- READY TO INSTALL: INCL. FILL & DRAIN HOSES, POWER CORD & NON-RETURN VALVE.
- ENERGY SAVING.
- SELF-CLEANING CYCLE.



Technical Specs

Macadams AM 900

	AM 900
Capacity per hour:	
Racks	60
Plates	1080
Glasses	2160
Power Supply	500V, 50 Hz, 3 phase
Booster Loading	6.15 kW
Total Loading	7 kW / 3 x 16 Amps
Tank Heating	2.5 kW interlocked
Capacity:	
Pump	0.7 kW / 350 L/min
Tank	21 Litres
Water Consumption	2.5 Litres / rack
Programme Cycle	60 sec / 90 sec / 120 sec
Noise Level	67 dB (A)
Dimensions: (mm)	
Closed	758 (l) x 815 (d) x 1510 (h)
Expanded	758 (l) x 815 (d) x 1995 (h)
Loading Height	440
Weight	105 kg
Optional	Tabling

1. Flexible Drain Hose: 2000 mm
20mm inner / 25 mm outer diameter
2. Fresh Water Connection:
Pressure Hose: 2000 mm = R 3/4" inside
Flow Pressure: 0.5 - 10 bar. Max. 60°C
Necessary Waterflow: 2500 mm
3. Power Cord: 2500 mm
4. Detergent Hose: 2000 mm
5. Rinse Agent Hose: 2000 mm

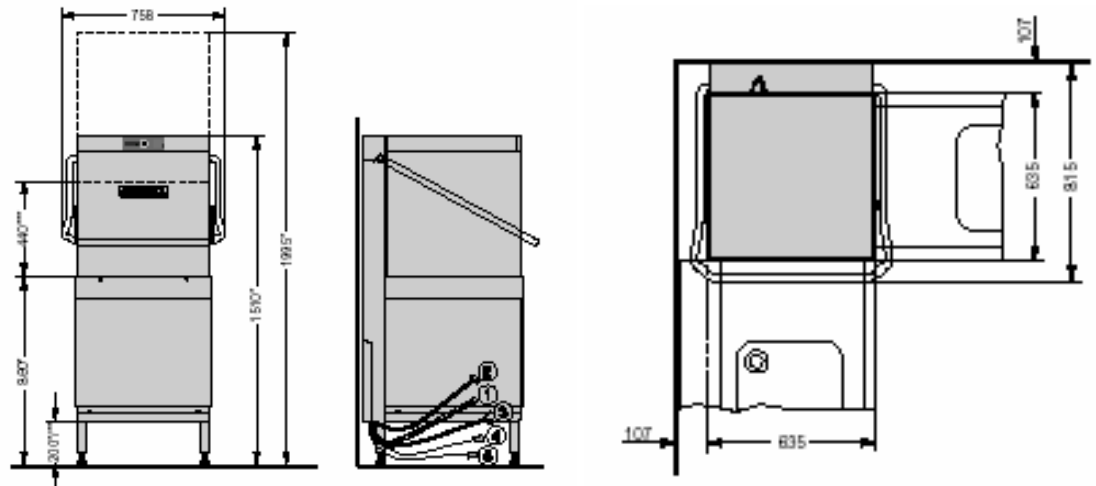

Contact Details

HEAD OFFICE, EXPORTS & CAPE TOWN BRANCH

Private Bag x7, Kuils River, 7579,
South Africa.

Tel : +27 (21) 907-1000

Fax : +27 (21) 907-1111

JOHANNESBURG BRANCH

Tel : (011) 472-4100

Fax : (011) 472-4154

DURBAN BRANCH

Tel : (031) 569-6290

Fax : (031) 569-6296

EMAIL

info@macadams.co.za

WEBSITE

www.macadams.co.za

We reserve the right to both
technical and design
modifications.

February 2009

The Company. The People. The Products.

